

1 Châssis galva
Ep 3 OGPM5050
en option

MATIERE INOX 304L OU 316L SUIVANT DEMANDE CLIENT
EP 1.5 FINITION MICROBILLE OU PEINT

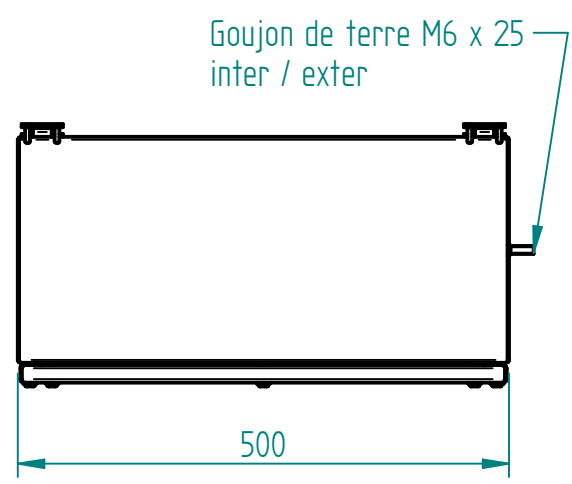
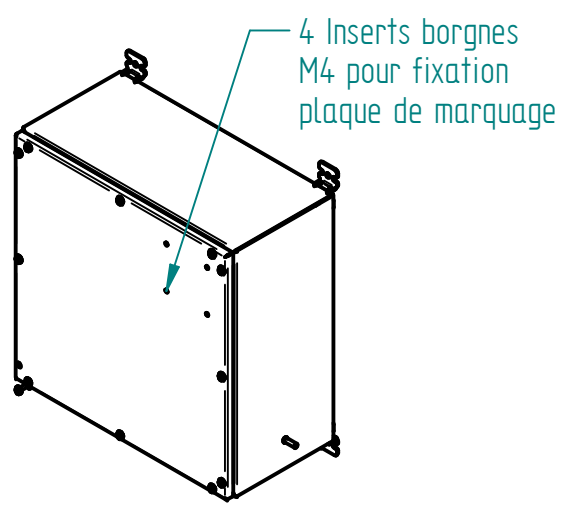
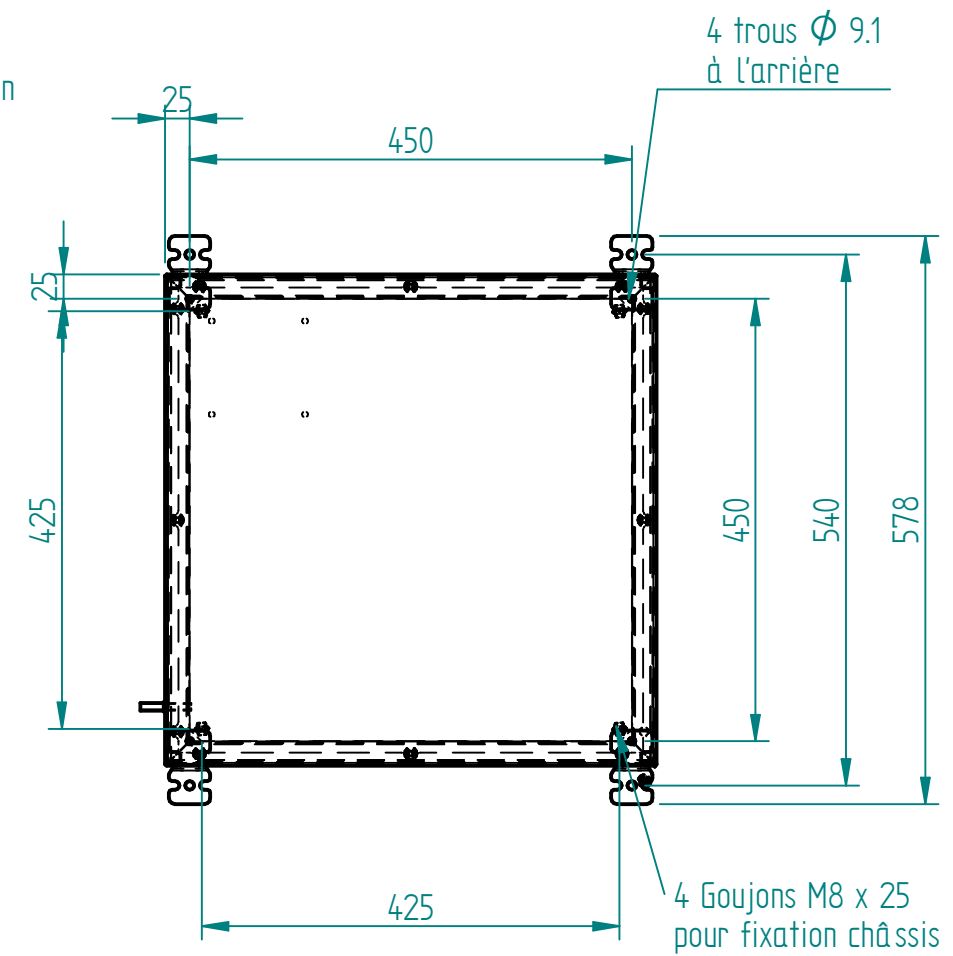
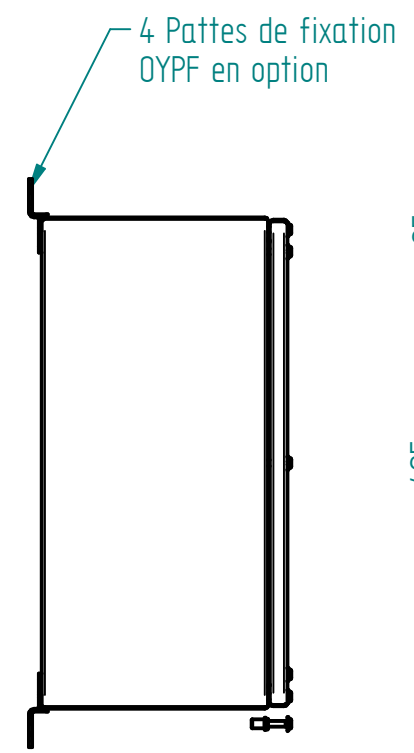
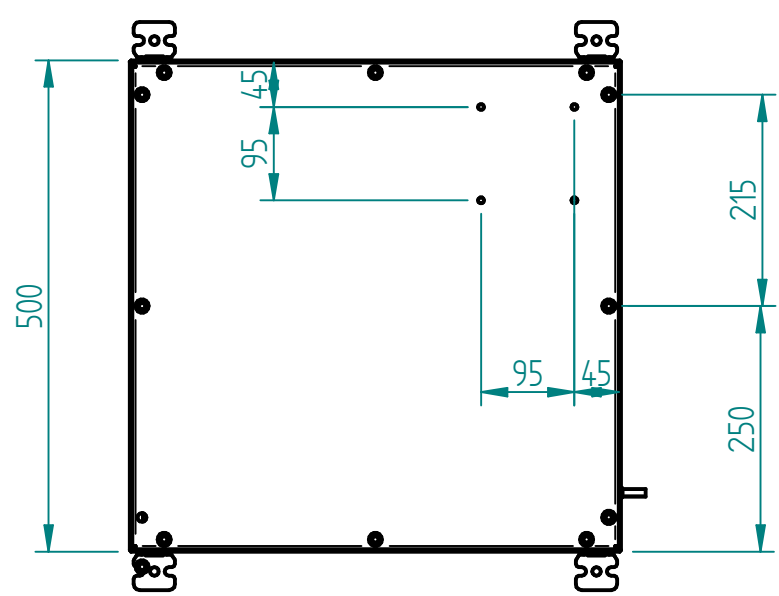
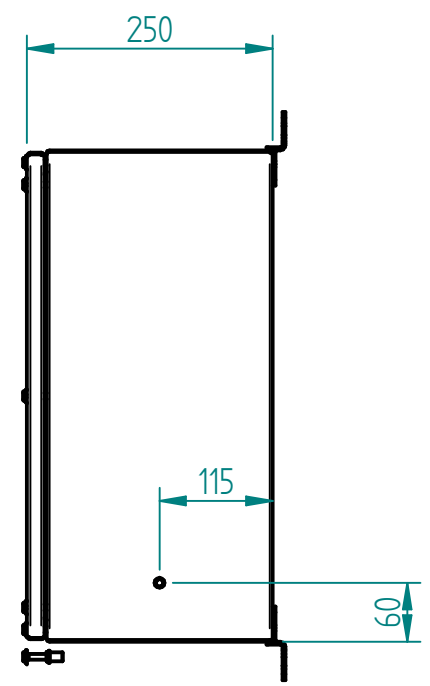

A	CLAVERIE	04/03/24	Création
Ind	Nom	Date	Commentaires
Matière :		Nom du projet :	
Echelle : 1:7.69		BOITIER-500x500x250	
Feuille : 1 / 1		Client :	
		Document n° :	
MARBORE		BXA505025 - BYA505025	